



## YL6 – Intelligent Temperature Controller

### INSTRUCTION

**Translators Note:** Google Translate is wonderful but time consuming.

**Much of this manual is a direct translation, but other parts (such as menu operations) have been edited to make them easier to understand. I accept no responsibility for any loss, damage or spelling errors. From here on out, you're on your own .**

using this product, please read the "manual" in order to operate correctly; and Keep for reference at any time.

The company produces series of YL-6 □ intelligent temperature control instruments. \

The production process in strict accordance with European CE standards control, instrumentation, circuit board plug-in, chip components, welding, and subject to temperature aging (-20 °C) → high temperature aging (+75 °C) →aging → conventional power parity-specific instrumentation function → function of the actual load detection five procedures to ensure the hardware with a wide range of anti-harmonic interference, and high or low temperature conditions, the critical point of the instrument component parameters stable performance, long working life and so on.

YL-6 □ Series Intelligent temperature controller temperature control software using fuzzy expert actuarial techniques, the use of "hyperbolic servo control" approach, the instrument has been established P, I, D value of the master curve, in the general conditions can be widely adapt to "normal" temperature environment, fast track, locking the temperature set point and the correct bias point; while some power is too large or too small for the heater, heating and cooling rate too fast or Pianman, high thermal coefficient or partial low, the same heating furnace parts and more distributed and due to different temperature points and the thermal effect of crosstalk and other "more special" temperature environment, by activating the instrument of "self-tuning" function, the instrument can be quickly transferred out of a set of applicable new temperature control environment to optimize P, I, D parameters, which effectively inhibit the temperature overshoot and fast climb, temperature control to achieve the best results to meet the temperature requirements of different environments. Widely used in injection molding, extrusion, blown film, blow molding, sealing, hot stamping, packaging, printing, food and other mechanical equipment; and temperature drying, metal heat treatment, boilers and other equipment for temperature control.

The products have passed CE certification.

#### Features:

\* One-button auto tuning function, without entering the instrument menu, straight press "  " key can activate the instrument self-tuning capabilities.

\* Automatic and manual temperature control can be rapid and smooth two-way conversion. Automatic P, I, D smart self-adjusting temperature control; to manually adjust the output power range of the percentage of work.

\* Thermocouple, RTD, standard signal such as a single configuration, K-type to the factory standard, other optional standard signal set, signal range set free.

\* Users can zero deviation from the more positive, zero software full-scale, single cold junction temperature, auto-zero amplifier, display accuracy up to ± 0.2% FS.

\* Master output option:

"R" - relay contacts (standard AC220V)AC contactor drive;

"S" - DC12V pulse level trigger-driven single-phase solid state relay

"I" - 4-20mA analog current-driven single-row, three-phase phase voltage regulator module;

"U" - DC0-5V analog voltage-driven single-row, three-phase phase voltage regulator module.

\* Road separate alarm contact output, the user can customize the four kinds of alarm mode.

Technical Specifications	Technical Data
Setting accuracy	Full Scale $\pm 0.5\%$ FS $\pm 1$ word
Accuracy	$\pm 0.2\%$ FS $\pm 1$ word
Sampling Frequency	2 times / sec.
Input Signal	Standard signal input (single signal): K-type Other standard signal input (single signal): E, S, J, Pt100, Pt100/0.1, Cu50 optional
Temperature Control	1 - intelligent, self-tuning control for factory P, I, D value, but when the temperature fluctuations at the critical point adjustable P, I, D parameters 2 - time proportional control, change: I = 0, D = 0, P = 30 other parameters unchanged 3 - position control, change: P = 0, I = 180, D = 30 other parameter values unchanged 4 - upper and lower range control, change: P = 0, change: "HY" back to the difference between the upper and lower range for the desired range of values, and enter the three menu (18) "Fr" proportional with the amount in advance to "0. "
Output Control	Switching control: "R" - Relay contact voltage (standard AC220V), "S" - 12VDC voltage pulse Analog control: "I" - 0-10mA ,4-20mA continuous current; "U" - 0-5VDC ,1-5VDC voltage continuous switching relay contacts, SSR zero trigger, zero-crossing trigger output control thyristor
Relay Contact Load	250VAC / 3A (resistive), 250VAC / 1A (inductive, Cos $\phi$ = 0.4)
Pulse Voltage Load	12VDC, maximum 40mA (for driving SSR, with short-circuit protection)
Analog Voltage and current load	(Standard) 0-5VDC ,4-20mA, load resistance Max = 500 $\Omega$
Alarm	Four kinds of upper and lower limit deviation alarm and upper and lower limit absolute value alarm free combination
Alarm Output Load	Relay contacts: 250VAC / 3A (resistive), 250VAC / 1A (inductive, Cos $\phi$ = 0.4)
Power Supply Voltage	180-240VAC, 50-60Hz $\leq 3$ W
Insulation Resistance	$\geq 10$ M $\Omega$ (test conditions 500VDC) (Main output for the current or non-contact voltage, do not test theinput / output terminal and the CT input resistance)
Ambient temperature and Humidity	-20 — +75 $^{\circ}$ C 35 — 85%RH

### 1. Front Panel Description:

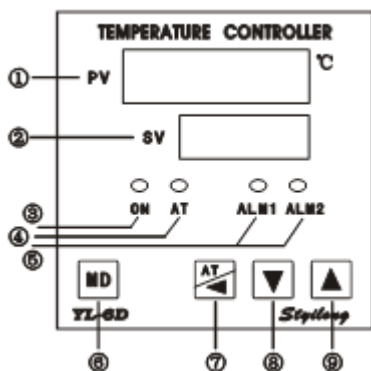

1. "PV" Display (red): Process Value (Real time temperature) / display the menu in the instrument software. Provides various functions prompt.
2. "SV" Display (green): Setting Value (Temperature Set point); Display instrument software menu of various functional parameters Number of default values, and self-tuning, or manually modified the new parameter values.
3. Master Output indicator: "ON" green light, the main control output; "ON" green light off, turn off the main control.
4. "AT" self-tuning light (yellow): instrument self-tuning function activated, the whole process of flashing.
5. "ALM1", "ALM2": two alarm indicator (red), independent on.
6. "MD" mode menu keys: Set temperature value / view into the instrument, set the parameters have been set Arguments confirmed.
7. "AT": self-tuning function keys / digital left key.
8. & 9. "▼", "▲" (left to right): values decrease key, key values increase.

## 2、Front Panel Instructions

- Standard display mode: after power meter, PV window shows the original set of sensor types, such as "K" type; SV window displays "1300", and then converting the window display when the PV Before the temperature measurements, SV window displays the preset settings.
- The standard display in the instrument, the instrument of the PV window sometimes flashes alternately following characters:  
 "HHHH": the input signal is over range, probably due to the sensor settings or using the wrong size, or open circuit caused by sensor input;  
 "LLLL": the input signal is negative over-range, probably due to the sensor settings or using the wrong size, polarity reverse, or short circuits caused by sensor input;  
 "Error": ADC overflow that instrument, the sensor may set or use the wrong size, polarity reverse, or sensor input open, short circuit caused;  
 When the instrument displays "HHHH", "LLLL" when, PV window flashing value is generally still correct, but the show "Error", then the value of PV window was wrong.

## 3. The functional parameters of the user operate the instrument for use:

- To change the Set Value (SV) setting;

Press and release the "MD" key. The right most digit will start flashing. Use "AT", "▼" and "▲" to adjust the value; then press "MD" to set.

- To Set or Modify the upper limit alarm, lower limit alarm value, and adjust the P, I, D and other parameters, you are required to enter the secondary menu.  
 To do this: Press "MD" mode menu button for about 6 seconds, the "PV" window will display "AL1" (upper limit alarm), the "SV" window will display the alarm value

Press the "MD" key to cycle through the parameters on order. . Use "AT", "▼" and "▲" to adjust the value; then press "MD" to set and advance to the next parameter.



When you are finished, Press and hold the "MD" button for about 6 seconds to return to control mode.

Specific functions and features a brief description (in Chinglish) of the prompt as follows:

Prompt	Name	Setting range	Description	Default
AL1	High limit Alarm Value	-199 ~ 9999	Limit absolute value alarm set point value, and maximum temperature alarm set point is higher than the primary deviation value.	50 °C
AL2	Lower limit Alarm value	-199 ~ 9999	Lower limit absolute value alarm set point value, and lower temperature alarm set point lower than the primary deviation value.	0 °C
Hy	Hysteresis	0 – 50	Set the master control for the upper and lower range control, and alarm point range hysteresis.	1 °C
P	Proportion Band (Heating Side)	0.0 – 999.9	Set the proportional band temperature control the size, "P" value is generally set to 30 °C, the heater for faster heating rate can be set to 50 °C. If the "P" value set to "0", or "digital" or "range" control.	30 °C
I	Integration Time (Re-adjusted Time)	0 – 3600	Integral time constant, when the temperature regulation rate fluctuations, I value should be increased; when the temperature for a long time can not eliminate the static error, the I value should be reduced. I value between the 60 ~ 240S temperature control system can adapt more.	180 S
D	Differential Time (Preset time)	0.0 – 999.9	Differential time constant, D values increase, the system helps reduce over-temperature; over the General Assembly to reduce the D value system anti-jamming capability. I value D value is generally 1 / 3 to 1 / 5.	30 S
T	Control Cycle (Heating Side)	1 – 99 S	Set heat control off cycle, is not allowed is set to "0." Relay output: 20 seconds; logic Level output drive SSR: 2 S; 0 - 5V, 4 - 20mA output drive voltage regulator module: 1 second.	20 S / 2 S / 1 S
SC	Measurement Correction	-50 - + 50	Used to correct the read circuit and the cold junction thermocouple (resistance) wire compensation arising from the measurement error.	0
At	Self-Tuning Function	0 – 1	"0" turn off auto-tuning; "1" activate self-tuning capabilities. (Also according to panel "AT" to activate)	0
Lock	Parameter Lock	0 - 2	"0": all parameters can be modified; "1": only modify the settings; "2": all parameters can not be modified.	0

#### 4. Instrument Engineers Parameter

This instrument has the facility for an experienced senior engineer or the user to set specific parameters of the third level menu. If you screw with these settings, the instrument may not act as you expect.

Access to the third level menu is as follows: Press and hold "MD" and " " keys simultaneously for about 6 seconds until "PASS" is shown in the "PV" window and "0000" is shown in the "SV" window. Then release the "MD" key first then the " " key. Enter the Parameter number into the "SV" window and press the "MD" key. The menu code will be shown in the "PV" window. Set the required value in the "SV" window and press the "MD" key to return to the "PASS" menu. Press "MD" again to return to control Mode.

Parameter	Menu Code	Function	Description	Range
14	ALP	Alarm	"0": upper and lower limits are absolute alarm; "1": upper limit for the deviation, the lower limit absolute value alarm; "2": maximum absolute value alarm, lower limit deviation alarm; "3": upper and lower limits are the deviation alarm.	0, 1, 2, 3. Factory Setting: 1.
15	Fsr	Maximum Setting	Set maximum SV temperature setting.	Factory Setting: K – 1300 °C
16	Hand	Auto/Manual Conversion	Set the "Hand" to "0": Automatic P, I, D regulation; set to "1": manual adjustment of power output percentage (press "shift" key to manually enter or exit the state, with the "plus / minus" button hand adjust the percentage of power output).	0 – 1. Factory Setting: 0.
17	Ctrl	Output Control	1, Rly: switch output control, AC voltage control relay contacts Contactor, 12VDC pulse voltage controlled single-phase solid state relay; 2,1-5V :4-20mA analog current output drive a single continuous three-phase phase voltage regulator module; 3,0-5V: DC0-5V analog voltage-driven single-row, three-phase phase voltage regulator module.	Factory setting: 1, R-type (AC contactor drive); 2, S-type (solid state relay driver); 3, I-type (drive voltage regulator module); 4, U-type (drive voltage regulator module).
18	Fr	Proportion with the amount of advance	Without changing the proportional band P-value conditions, the proportion with a forward, can effectively reduce the heat on the first impulse inertia range.	0 – 100. Factory Setting: 15.
19	Tt	Fuzzy tracking the amount of temperature	Temperature in some special occasions, can show the value of the instrument temperature control settings of ± Tt value range, and steady progress by setting (nothing to do with the actual temperature).	0 – 20. Factory Setting: 15.
20	P0	Initial power output meter	In some instruments often need to pass off switch where the temperature can be repeated to reduce the instrument power on the initial state due to uncertainty caused by the temperature on the red, down, back and forth fluctuation.	0 – 100. Factory Setting: 10%
21	P1	After entering the initial ratio of output power with	When the temperature range of the proportional band the first time, give an initial output power meter, which can effectively reduce the temperature overshoot, and speed up the instrument at the critical point in the set into a stable control state.	0 – 100. Factory Setting: 10%
22	0V	Output allows the suspension of over-temperature value	When the temperature exceeds the set temperature ± 0V value (and the temperature continued to rise in the state), the meter will automatically stop the output.	0 – 10. Factory Setting: 1°C

1. Wiring Precautions

- a. Thermocouple input, use the correct type of compensating wire.
- b. RTD input, use a 3 wire RTD or connect a link between the two RTD(-) terminals.
- c. Keep the input signal wiring away from instrument power cord, power supply lines and load lines to avoid noise and electromagnetic interference shielding.

2. Terminal Map

(1) YL-6A wiring diagram

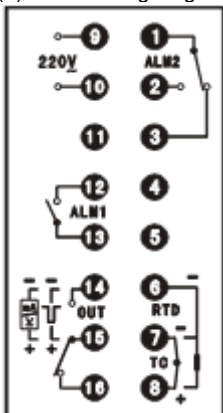

(2) YL-6B wiring diagram

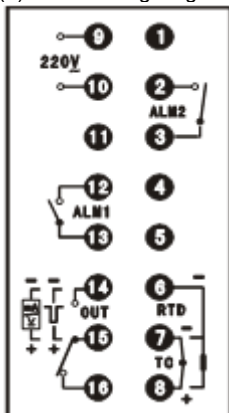

(3) YL-6D wiring diagram

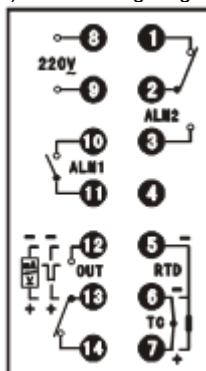

(4) YL-6E wiring diagram

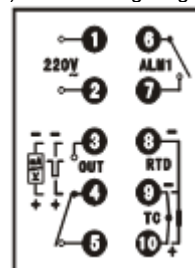

Please refer to the following selection table to determine whether the delivered product meets your specifications.:

**YL - 6**   /

仪表系列      仪表型号

规格	W (宽)	H (高)	L (长)	M	N	a	b
A	96	96	60	91	91	+0.8 92	+0.8 92
B	48	96	60	43	91	+0.6 45	+0.8 92
D	72	72	80	67	67	+0.7 68	+0.7 68
E	48	48	86	43	43	+0.6 45	+0.6 45

仪表规格 / 尺寸

**辅助控制:**  
 1、A1: 只第一路报警控制;  
 2、A1、A2: 二路报警控制;  
 两路独立输出, 功能可自定义.

**输入信号: (单一标准信号输入)**  
 1、热电偶: K、E、S、J;  
 2、热电阻: Cu50、Pt100、Pt100.1;

**主控制方式:**  
 R—继电器触点输出, 250V/3A;  
 S—电压脉冲输出, 接SSR固态继电器, 12VDC/40mA;  
 I—连续电流4~20mA输出, 接移相调压模块;  
 U—连续电压0~5V输出, 接移相调压模块.

Notes:

1. Meter should be installed in the following environment:  
 Atmospheric pressure 86 ~ 105KPa;  
 Temperature 0 ~ 50 °C;  
 Relative humidity 45 ~ 85% RH.
2. Install meters should pay attention to the following conditions:
  - a. Rapid changes in temperature may cause condensation.
  - b. Water, oil, chemicals, smoke or steam and other corrosive, flammable gas pollution.
  - c. Excessive dust, salt or metal powder. D, the main structure of the direct vibration or shock.
  - d. Multiple meter installation:
    - i. Horizontal spacing, no less than 25mm between units.
    - ii. Vertical spacing no less than 30mm between units.



YL-6E family intelligent temperature controller Standard Edition

**Product Detail**

**First, an overview of instrument**

Our production of YL-6EI, YL-6EU, YL-6ES, YL-6ER series intelligent temperature control instrument, the production process in strict accordance with European CE standards control, instrumentation, circuit board plug-in, chip components, welding, and subject to temperature aging (-20 °C) → high-temperature aging (+75 °C) → aging → conventional power parity-specific instrumentation features → actual load control test five procedures to ensure the hardware with a wide range of anti-harmonic interference, as well as high temperature or low temperature conditions, the critical point of the instrument component parameters stability, and long working life and so on.

YL-6EI, YL-6EU, YL-6ES, YL-6ER Series Intelligent temperature controller temperature control software using fuzzy expert actuarial techniques, the use of "hyperbolic servo control" approach, the instrument has been established P, I, D value of the master curve, in the general conditions can be widely adapted to a variety of "normal" temperature environment, fast track, locking the temperature set point and the correct bias point; while some power is too large or too small for the heater, heating and cooling rates partial fast or Pianman, high or low thermal coefficient, the same heating furnace parts and more distributed and due to different temperature points and the thermal effect of crosstalk and other "more special" temperature environment, by activating the instrument of "self-tuning" function, the instrument can quickly tune out a new application environment to optimize temperature control P, I, D parameters, which effectively inhibit the temperature on the red and quickly stabilized, temperature control to achieve the best effect to meet different environmental temperature requirements. Widely used in injection molding, extrusion, blow molding, sealing, stamping, food, packaging, printing machinery and equipment; and temperature drying, metal heat treatment, boilers and other equipment for temperature control.

**This series of intelligent temperature control instrument has passed the European CE standard certification testing.**

**Second, product characteristics**

- \* One-button auto tuning function, without entering the instrument, single, directly on the panel on "AT" button you can activate auto-tuning the instrument.
- \* Fast auto-tuning, "AT" auto-tuning process is quick and smooth, with excellent self-tuning, temperature control and high accuracy.
- \* Users can zero deviation from the more positive, zero software full-scale, single cold junction temperature, auto-zero amplifier, display accuracy up to  $\pm 0.2\%$  FS.
- \* Master output option  
 "I" - Analog 4-20mA continuous current drive single, three-phase phase voltage regulator module;  
 "U" - a continuous analog voltage 0-5VDC drive a single, three-phase phase voltage regulator module;  
 "S" - the pulse voltage DC12V drive solid state relay;  
 "R" - Relay contact output control AC contactor.
- \* Road separate alarm contact output, the user can customize the four kinds of alarm mode.

**Third, technical indicators and technical parameters**

- 1, setting accuracy: full scale  $\pm 0.5\%$  FS  $\pm 1$  word.
- 2, Accuracy:  $\pm 0.2\%$  FS  $\pm 1$  word.
- 3, the sampling frequency: 2 times / sec.
- 4, input signal: standard input (one signal): K-type  
 Other standard signal input (single signal): E, S, Cu50, Pt100, Pt100/0.1 optional.
- 5, temperature control:  
 (1) intelligent self-tuning control for factory P, I, D value, but when the temperature fluctuations at the critical point adjustable P, I, D parameters;  
 (2) time proportional control, change: I = 0, D = 0, P = 20 parameters unchanged;  
 (3) position control, the change: P = 0, I = 150, D = 30 parameter values unchanged;  
 (4) upper and lower range control, change: P = 0, the third-level menu change (16) "HY" back to the difference between the upper and lower range for the desired range of values, while (21) "Ft" ahead of the proportional band amount to "0."
- 6, output control:  
 (1) Analog control "I" type: 4-20mA continuous output current drive phase voltage regulator module;  
 "U" shape: 0-5VDC output voltage drive continuous phase voltage regulator module.  
 (2) The volume control switch "S" type: output DC12V pulse voltage driven solid-state relay;  
 "R" type: Relay contact output control AC contactor.
- 7, relay contact load: 250VAC / 3A (resistive), 250VAC / 1A (inductive,  $\text{Cos}\phi = 0.4$ ).
- 8, pulse voltage load: 12VDC, maximum 40mA (for driving SSR, with short-circuit protection).
- 9, analog voltage and current load: (Standard) 0-5VDC, 4-20mA, load resistance Max = 500Ω.
- 10, the alarm function: Four upper and lower limit deviation alarm, upper and lower limit absolute value alarm, can be freely combined.
- 11, alarm output load: Relay contact - 250VAC / 3A (resistive); 250VAC / 1A (inductive,  $\text{Cos}\phi = 0.4$ ).
- 12, power supply voltage :80-260VAC ,50-60Hz;  $\leq 5W$ .
- 13 Insulation resistance:  $\geq 10M\Omega$  (test conditions 500VDC) (main output for the current or non-contact voltage, do not test the input / output terminal and the CT input resistance).
- 14, ambient temperature and humidity: -20 - +75 °C; 35 - 85% RH.

**4, YL-6ER:**

- "YL" - Model;
- "6" - 6000 Series;
- "E" - Dimensions: 48mm x 48mm x 86mm (hole size: 45mm x 45mm);
- "R" - output control for the relay contacts: 220V/DC (standard).